

PTFE Expansion Joint

Another non-metallic type of expansion joint is available, manufactured of Teflon. This type of expansion joint has been used with highly corrosive medias, with glass or plastic piping or in heating ,ventilating and air conditioning applications, where space is a premium.

1. Construction

A flexible Teflon pipe connector is a 2, 3, or 5 convolution expansion joint consisting of a Teflon FEP, PTFE or PFA, reinforced with metal rings and attached with ductile iron flanges, designed to absorb movement and vibration in a piping system.

2. Performance Characteristics

1. Chemical Resistance. molded or machined Teflon connectors are used in corrosive applications due to the inherent resistance of Teflon to a vast range of chemicals.

2. Vibration Absorption. Teflon connectors are sometimes used in HVAC applications to absorb vibration and attenuate noise.

3. Temperature Limits. Teflon connectors can withstand temperatures as high as 450°F and as low as -10°F.

Note: Temperatures of the system significantly affect the pressure rating of the connectors.

4. Pressure Limits. Pressure vary widely depending upon system temperature.

5. Length. Teflon connectors are available in nominal pipe sizes from 1" to 24" diameter.

3. Construction Detail

1. Body. The body of the Teflon connectors are manufactured of 100% FEP, PTFE or PFA Teflon. The Teflon may be colored or opaque/temperature relationship.

2. Reinforcing Rings. Metal reinforcing rings of stainless steel, Monel or other metals may be used to add strength between the convolutions.

3. Flanges. The flanges are normally manufactured of ductile iron, coated or plated with a rust-inhibiting paint. Flanges of other materials are available upon request. The Flanges are normally drilled with ANSI B16.5 150# tapped holes. Some manufacturers also provide drilling for glass pipe flange bolting(Corning Style #2)

4. Control Rods. All Teflon connectors are supplied with factory set control rods. The control rods are set to prevent over-extension during operation.

5. Stabilizing Rings. Some manufacturers offer styles of expansion joints with stabilizing rings to prevent squirm.

6. Liners. Internal sleeves of Teflon are sometimes available for abrasive or high velocity flow rate applications. Consult each manufacturer for information.

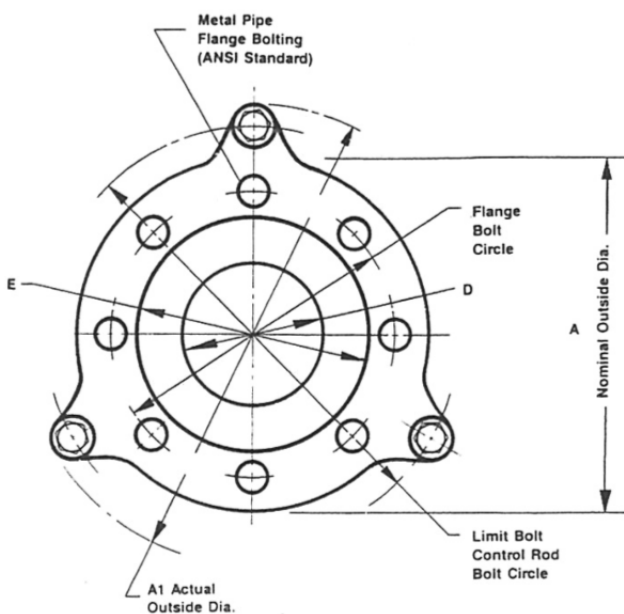

All Teflon Joint Flange



4. Types of Connectors

1. Coupling(PER-TC). A two-convolution connector designed for minimum movements.

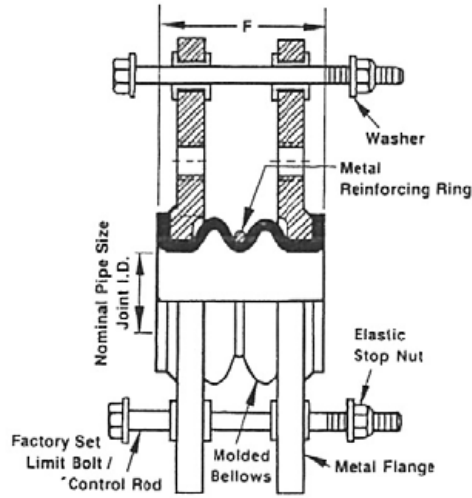

2. Expansion Joint(PER-TE). A three-convolution connector designed for easy movement and ease of system installation.

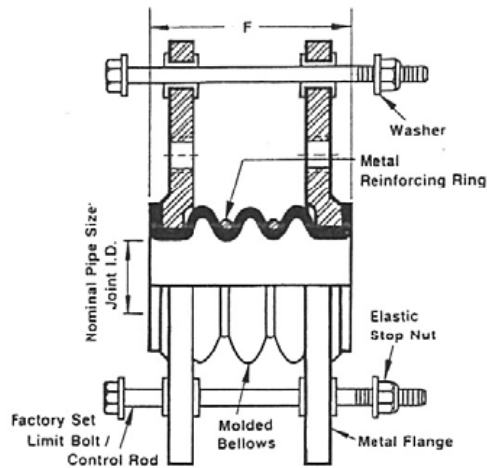

3. Bellows(PER-TB). A five-convolution connector designed for maximum movements and vibration elimination.

